

**zero**  
HOME AUTOMATION

# Z01 - SLIDING GATE MOTOR

SUPPLY 230-24V



IT | EN | FR

Z01.REV01.2018

USER MANUAL AND CONFIGURATION

zero  
HOME AUTOMATION

## INDEX

- 01. SAFETY INSTRUCTIONS
- 02. OPERATOR  
TECHNICAL SPECIFICATIONS  
DIMENSIONS
- 03. INSTALLATION  
INSTALLATION DIMENSIONS  
INSTALLATION STEPS  
TYPICAL INSTALLATION
- 04. MAINTENANCE  
MANUEL RELEASE
- 05. TROUBLESHOOTING

## 01. SAFETY INSTRUCTIONS

## ATTENTION:

- To ensure the safety of people, it is important that you read all the following instructions. Incorrect installation or incorrect use of the product can cause physical injury and material damage.
- Keep these instructions in a safe place for future reference.
- This product was designed and produced strictly for the use indicated in this manual. Any other use, not expressly indicated here, could compromise the good condition/ operation of the product and/or be a source of danger.
- ZERO SRLS. is not responsible for the improper use of the product, or other use than that for which it was designed.
- ZERO SRLS. is not responsible if safety standards were not taken into account when installing the equipment, or for any deformation that may occur to it.
- ZERO SRLS. is not responsible for the safety and proper operation when using components not sold by them.
- Do not make any modifications to the operator components and / or their accessories.
- Before installation unplug the automatism from the source of power.
- The installer must inform the client how to handle the product in case of emergency and provide this manual to user.
- Keep remote controls away from children, to prevent the automated system from being activated involuntarily.
- The customer shall not, under any circumstances, attempt to repair or tune the operator .Must call qualified technician only.
- Connect the automatism to a 230V plug with ground wire.
- Operator for outdoor and indoor use.

02. OPERATOR

TECHNICAL SPECIFICATIONS

Z01 specifications are as follow:

	Z01.01	Z01.01.24	Z01.02	Z01.02.24
Power Supply	230Vac 50/60Hz	24Vdc	230Vac 50/60Hz	24Vdc
Power	250W	50W	400W	50W
Current	1,4 A	1-3 A	2A	1-3 A
RPM	1400	2000	1400	2000
Capacitor	10µF	-	12.5µF	-
Maximum gate weight	600 kg		1000 kg	
Force	1200 N		2300 N	
Noise level	LpA <= 50 dB (A)			
Operating temperatures	-25°C to 65°C			
Thermal protection	150°C	-	150°C	-
Protection class	IP44			
Working frequency	25%	INTENSIVE	25%	INTENSIVE
Opening time	10 m/s	12 m/s	10 m/s	12 m/s

DIMENSIONS

The dimensions of automatism Z01.01 || Z01.02 are the following:

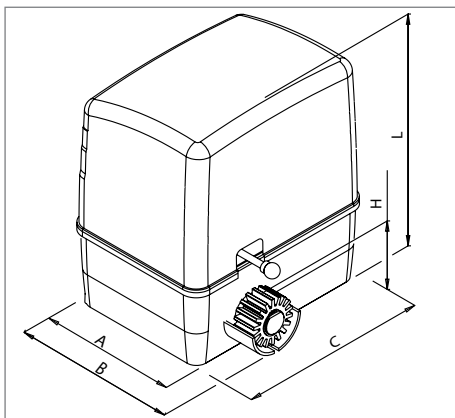

	Z01.01	Z01.02
A (mm)	170	170
B (mm)	210	210
C (mm)	230	250
L (mm)	70	70
H (mm)	265	280

### 03. INSTALLATION

#### INSTALLATION DIMENSIONS

During installation you will need to open the motor cover, to access various components on the inside. For this, loosen the screw until the cover is free to be removed.

For correct operation of the automatism, it is necessary to pay attention to the dimensions given in the following images.

#### INSTALLATION STEPS

On the Illustrated pictures below are the dimensions for the installation of the automated system.

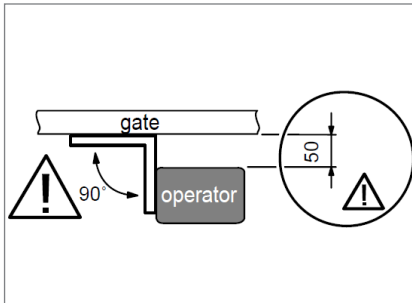

01. Position the operator 50 mm from the edge of the gate and perfectly square at an angle of 90° and mark the place to make the holes for the bushings. Must make the mark at the center of the oval holes

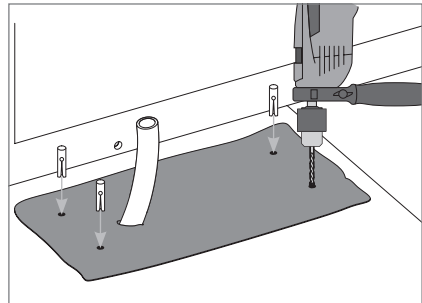

02. Drill four holes with  $\varnothing 18\text{mm}$  on foundation. Place M10 steel anchors on the holes. Align it parallel to the gate leaving a distance of 50 mm and anchor the operator.

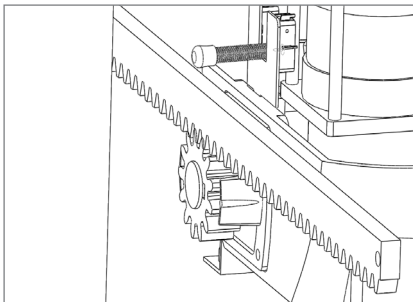

03. Mesh the rack with the pinion, leaving 1 to 2 mm backlash between the teeth. This backlash must remain constant over the entire length of the rack. Fix / weld the rack to the gate.

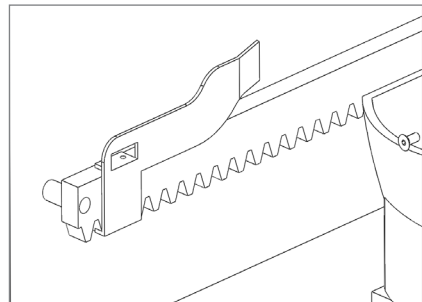

03. Bring the gate to its open position manually, stopping at a distance of 3cm from the mechanical limit stop. Slide the limit stop bracket along the rack until causing the limit stop to trip. Fix the bracket to the rack with the dedicated screws. Perform the same operation for the closing limit stop.



It is very important that these dimensions are respected! Only this way can be assured the correct functioning and durability of the operators!

During the course of the gate, all elements of the rack must mesh properly with the pinion! All rack supports must be welded at the gate. Do not use mass or other types of lubricant between rack and pinion!

#### TYPICAL INSTALLATION

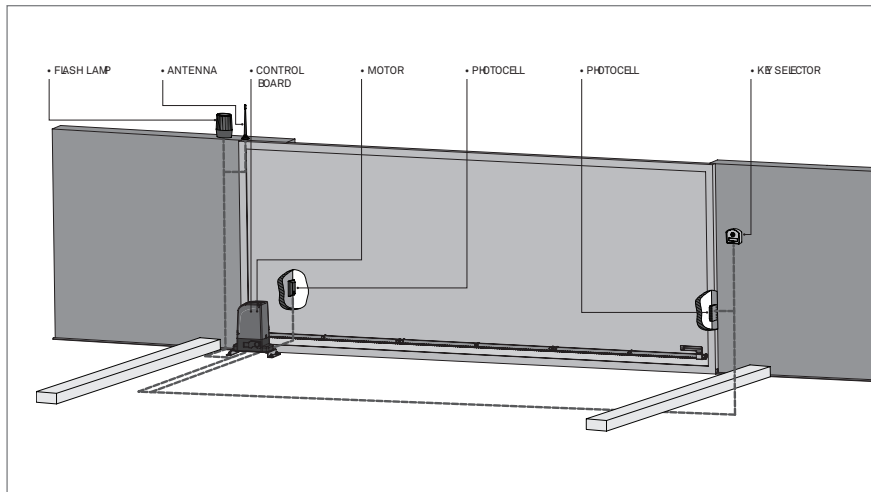

It is important to use mechanical stoppers in the opening and closing position of the gate. If not respected, components of the automation may suffer efforts for which they were not prepared, and as a result will be damaged.

It is important to use junction boxes for connections between motors, components and control unit. All cables must enter and exit on the bottom of the junction and control board box.

#### 04. MAINTENANCE

Check that the distance between rack and motor remains unchanged and this engages the teeth of the pinion of the engine correctly (over time can happen some distortion).

Lubricate all systems/axis of movement of the gate. Lightly lubricate with spray the rack and pinion.



**Check all screws of the automation such as the fixing plate to the ground, the plates of the limit switches, motor and the gear rack.**

#### MANUAL RELEASE

To open manually the gate in case of electric power failure or in case of damage, follow the below steps:

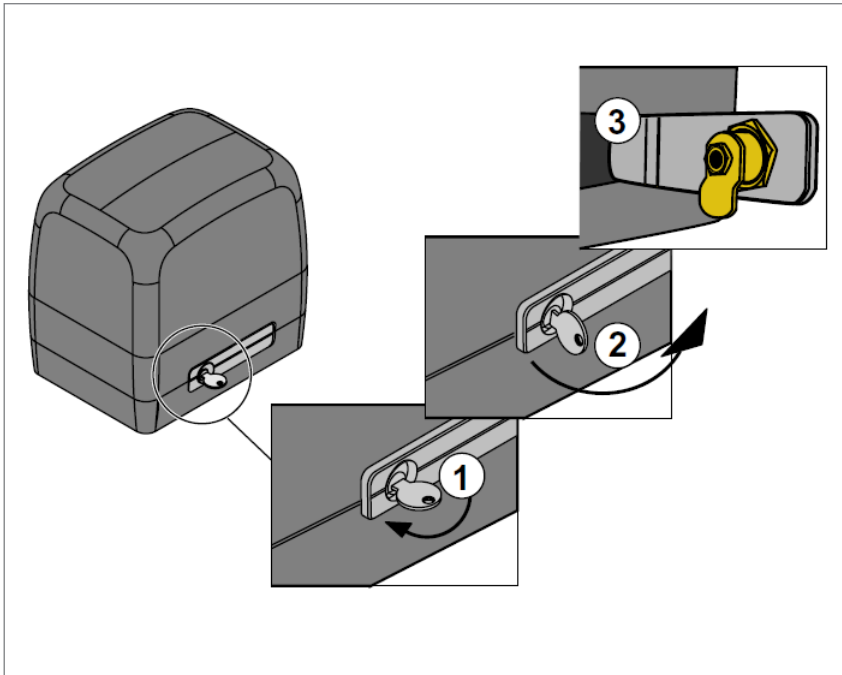

- 01 • Open the protection cover to access the key hole for the release.
- 02 • Insert the key and turn it 90°.
- 03 • Pull the lever towards the outside, and you can now open/close the gate manually.

**NOTE :** So that the automation will operate normally, close the unlock and turn the key to the original position.

05. TROUBLESHOOTING

Problem	Procedure	Behavior	Procedure II
Door doesn't work	Make sure you have 230V power supply connected to control board and if it is working properly.	Still not working.	Consult a qualified ZERO technician.
Motor doesn't move but makes noise	Unlock motor and move the gate by hand to check for mechanical problems on the movement	Encountered problems?	Consult an experienced gate expert.
		The gate moves easily?	Consult a qualified ZERO technician.
Motor opens but doesn't close	Unlock motor and move the gate by hand to closed position. Lock motor again and turn off power supply for 5 seconds. Reconnect it and send start signal using transmitter.	Gate opened but didn't close again.	Check if there is any obstacle in front of the photocells;
			Check if any of the control devices (key selector, push button, video intercom, etc.) of the gate are jammed and sending permanent signal to control unit;
			Consult a qualified ZERO technician.
Gate doesn't make complete route	Unlock motor and move gate by hand to check for mechanical problems on the gate	Encountered problems?	Consult an experienced gate expert.
		The gate moves easily?	Consult a qualified ZERO technician.



Discovering the origin of the problem				
1. Open control board and check if it has 230V power supply	3. Disconnect the motor from control board and test them by connecting directly to power supply in order to find out if they have problems.	4. If the motor works, the problem is on the control board. Pull it out and send it to our ZERO technical services for diagnosis.	5. If the motor doesn't work, remove them from installation site and send to our ZERO technical services for diagnosis.	
2. Check input fuses				
Check all motion axis and associated motion systems related with the motor and the gate to find out what is the problem.				
1. Check capacitors, testing operator with new capacitors;	2. If capacitors are not the problem, disconnect motors from control board and test them by connecting directly to power supply in order to find out if they have problems.	3. If the motors work, the problem is from control board. Pull it out and send it to our ZERO technical services for diagnosis;	4. If the motors don't work, remove them from installation site and send to our ZERO technical services for diagnosis	
<p>All ZERO control boards have LEDs that indicate the functioning of connections to allow easy diagnosis of faults. All safety devices LEDs (DS) in normal situations remain On. All "START" circuits LEDs in normal situations remain Off.</p> <p>If LEDs devices are not all On, there is some security systems malfunction (photocells, safety edges), etc.</p> <p>1 • Close with a shunt all safety systems on the control board (check manual of the control board in question). If the automated system starts working normally check for the problematic device.                  2 • Remove one shunt at a time until you find the malfunction device .                  3 • Replace it for a functional device and check if the motor works correctly with all the other devices. If you find another one defective, follow the same steps until you find all the problems.</p>				
1. Check capacitors, testing with new capacitors;	3. If the motor doesn't work, remove it from installation site and send to our ZERO technical services for diagnosis.	4. If motor work well and move gate at full force during the entire course, the problem is from controller. Set force using P1 button on the board. Make a new working time programming, giving sufficient time for opening and closing with appropriate force.	5. If this doesn't work, remove control unit and send it to ZERO technical services services.	
2. If capacitors are not the problem, disconnect motor from control board and test it by connecting directly to power supply in order to find out if it is broken;				
Check all motion axis and associated motion systems related with the motor and the gate to find out what is the problem.				
<p>NOTE: Setting force of the controller should be sufficient to make the gate open and close without stopping, but should stop and invert with a little effort from a person. In case of safety systems failure, the gate shall never cause physical damaged to obstacles (vehicles, people, etc.).</p>				



zero  
HOME AUTOMATION

zero  
HOME AUTOMATION

ZERO SRLS  
Via ROMA 25/A ALTAVILLA VIC.  
ITALIA  
info@miozero.it - www.miozero.it